

PERFORMANCE MATERIALS FOR PASSIVE EV BATTERY THERMAL MANAGEMENT

**CHARGE FASTER, LENGTHEN CELL CYCLE LIFETIME
IMPROVE DRIVING RANGE &
MITIGATE THERMAL RUNAWAY**



The batteries that power electric vehicles (EVs) can be thought of as miniature chemical reaction chambers—chambers that generate large amounts of heat. So, where does this heat come from? EV batteries produce heat when they're actively discharging, when they're being charged, and even when they're just sitting there "doing nothing." If this excess heat isn't removed, it will cause problems—lower driving range, shorter battery lifetime, and even fire.

In an industry that is still rapidly evolving, there is no uniform way that manufacturers are attacking thermal management challenges and no catch-all thermal management material that has emerged as the clear leader. Each has its pluses and minuses that every manufacturer will need to evaluate as it relates to its own pack design.

The solutions, however, can be cataloged into four discrete buckets which can be used individually or as part of a combined solution. These are **immersion**, **isolation**, **insulation**, and **spreading**. Immersion, which utilizes mechanical pumping and cooling systems (active thermal management) is the more costly and complex way of addressing heat-related issues. Less complicated and lower cost are the passive isolating, insulating, and spreading heat management methods that incorporate the performance materials we convert at JBC.

Passive thermal management relies on the inherent physical properties of performance materials. For example, materials with high temperature resistance and inherently low thermal conductivities excel when it comes to the isolation of extreme heat. Other materials leverage properties like thermal conductivity, emissivity, and phase change chemistry to effectively move the heat away from sensitive components and into the surrounding environment and/or spread it out over a wider surface to minimize hot spots within the battery pack.

Regardless of their functionality, performance materials are typically produced in large rolls or sheets. To be utilized in an EV battery, these components must first be transformed into custom solutions by a specialized converter—enter JBC Technologies. We will combine the base materials into the final form, before cutting and packaging the components so they are ready for use by the battery module and pack manufacturers.

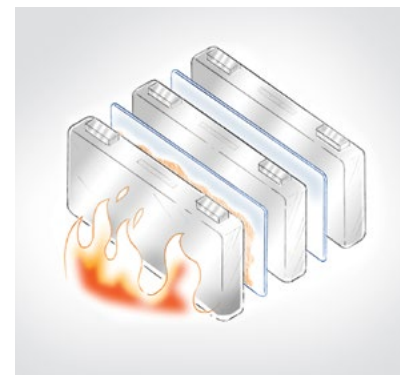

This paper will discuss these passive materials and how JBC Technologies fits within the EV battery manufacturing value chain.

WHAT IS THERMAL MANAGEMENT

and Why Does it Matter?

Before we dive into the details, let's take a step back to review the whats and whys of thermal management. At its most basic, thermal management—whether passive or active—is about putting controls in place to ensure that the cells of the battery operate within a narrow, optimal temperature window. EV batteries prefer to operate at or around the 70 °F (≈21 °C) mark making temperature extremes at both ends of the thermometer quite problematic. As the batteries generate heat during charging and operation, effectively managing this extra heat energy becomes critical. Unless this excess heat is spread out and removed, isolated pockets of high temperature can form leading to individual battery cell failure and potentially catastrophic thermal runaway.

- **Low Temperature:** <68 °F (20 °C) - slows down battery performance and decreases power, acceleration, and driving range. Charging the batteries at low temperatures also increases the potential for battery damage.
- **High Temperature:** >86 °F (30 °C) - degrades batteries and can diminish overall battery performance, reducing cell lifetime and increasing the risk of fire.

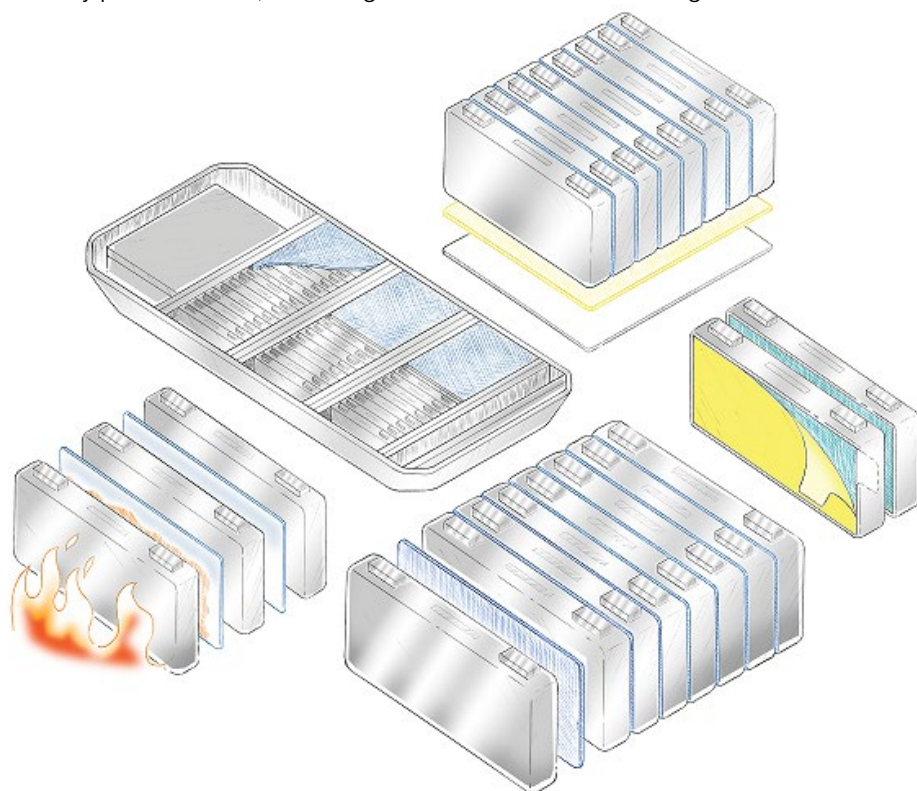

Types of specialty materials JBC can convert for use in and around the EV Battery

INSULATE

Aerogels

Lightweight passive fire protection, thermal runaway mitigation (e.g., Aspen Aerogels PyroThin)

Ceramic Papers

Cell compression, thermal runaway mitigation (e.g., Morgan Advanced Materials EST™ Papers)

SPREAD

Flexible Graphites

Thin, lightweight heat spreading (e.g., NeoGraf eGraf® SpreaderShield™)

Phase Change/Intumescent Materials

Thermal management, fire blocking (e.g., Saint-Gobain Norseal® FS1000 foam)

Gap Pads

Space-filling, thermal runaway mitigation (e.g., 3M 5591 Thermally Conductive Silicone Interface Pad)

SHIELD

Micas

Thermal barriers, insulators, high-temperature protection, dielectric strength (e.g., Morgan Advanced Materials' EST Paper M)

Microcellular Polyurethanes

Cell module cushioning, cell compression, dielectric strength (e.g., Roger's PORON® EVExtend battery pad)

Polyamide Papers

Electrical insulation, dielectric strength, heat shielding (e.g., DuPont™ Nomex® 410 papers)

Polypropylene Sheets

Electrical insulation, dielectric strength, thermal barrier (e.g., ITW Formex® GK flame retardant insulation)

“By including proper thermal management material, you'll pull heat away from the cells as fast as you generate it. This not only allows you to charge the battery faster and extends the life of the cells, but it also gives you a much safer battery.”

-Bret Trimmer, Applications Engineer for NeoGraf Solutions.

PASSIVE THERMAL MANAGEMENT

In and Around the Battery Pack

There are several areas within and around the EV battery pack where custom die-cut solutions from JBC can be used as part of the passive thermal management solution and they can be bucketed into three primary application areas: Cell-to-Cell, Module-to-Module, and Pack-Level.

Cell-to-Cell

Cell-to-cell thermal protection involves the spaces between and around the individual battery cells. There are multiple performance materials—used either alone or laminated together into multi-functional material stacks—that can be used to achieve one or more thermal management objectives.

Take, for example, how one might choose to layer flexible graphite with a high-temperature mechanical pad. This multi-layer construction should feature the exceptional heat spreading capabilities of the graphite along with the elevated temperature and compression resistance of the pad, both combining to protect battery cells from the mechanical damage that could occur when cells expand and contract during charge and discharge cycles. Depending on material selection, the adhesives that are used to laminate the materials together can also enhance the overall performance of the material by adding dielectric strength and flame resistance.

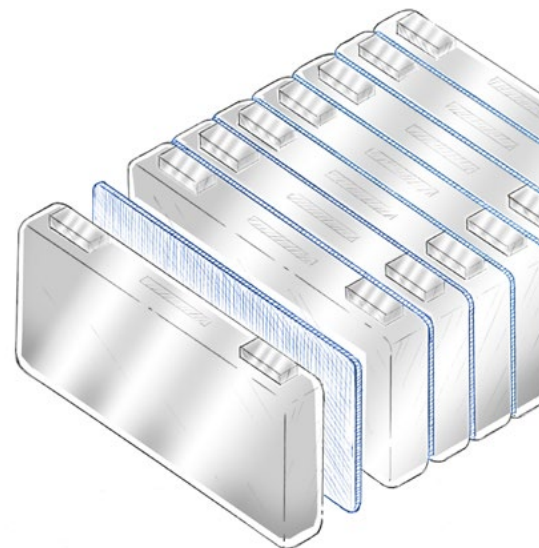

MATERIAL SPOTLIGHT

EST™ (Energy Storage Technology) Compression Papers from Morgan Advanced Materials are designed to accommodate the cyclical expansion of both pouch and prismatic cells and prevent or delay the propagation of heat during thermal runaway. These low biopersistent papers feature classification temperatures from 2012 – 2372 °F (1100 – 1300°) strong compression resistance and are non-flammable, UL94 V-0 rated.

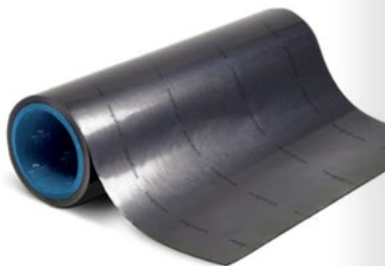

MATERIAL SPOTLIGHT

eGraf® SpreaderShield™, from NeoGraf, is 30% lighter than Aluminum and 80% lighter than Copper and spreads heat up to 4x more effectively than Copper and 7x more than Aluminum. It can be used to maintain cell temperature uniformity during charge and discharge cycles. It can be encapsulated in PET (Mylar), die-cut, and used as a stand-alone product or laminated to a material such as Rogers PORON® or EST™ Compression Papers and used as an integral layer of a multi-functional material stack.

Module-to-Module

Another area where custom solutions crafted from performance materials can contribute to effective passive thermal management is at the module level. Module-level thermal management is focused on preventing the transfer of heat from module to module in the event of a fire. This has the effect of slowing the spread of heat into the passenger cabin in the event of a thermal runaway. Modules can also be insulated against the spread of RFI noise that can disrupt sensitive electronics.

MATERIAL SPOTLIGHT

UL94 V-0 rated, **EST™ M Paper from Morgan Advanced Materials**, was specifically made for use in module-to-module protection scenarios. It is a mica-laminated paper designed to offer strong performance in high-temperature environments. The mica facing allows for higher dielectric strength values and enables the spread of the heat on the hot face in the x and y directions. The insulating **Superwool® Paper** is intended to prevent the heat from spreading in the z-direction to the cold face.



“Incorporating multiple uses or multiple mechanisms into a single part is key to reduce weight, cost, and range of EVs all while increasing safety, whether that be through material science development or conversion technologies.”

*-Jensen Plummer R&D Engineer II:
Automotive and LiB Development for Morgan Advanced Materials*

Pack Level

Pack level protection of the EV battery system is often seen as the last line of defense against thermal runaway. It is there to provide added protection between the battery and passenger compartment, containing any excess heat brought about by cell failure and giving the passengers ample time to exit the vehicle in an emergency. Die-cut materials used for this purpose are often inserted between the lid and the battery pack. Materials can also be used at this level to shorten battery warm-up time, prevent heat migration into the passenger cabin, and insulate against external temperatures.

Applications:

- **Insulation** – Aspen Aerogel PYROTHIN™ ATB 1000
- **Hot Spot Spreading** – NeoGraf SpreaderShield™ flexible graphite
- **Thermal Runaway Mitigation** – Nomex® SafePak™ Flame Barrier

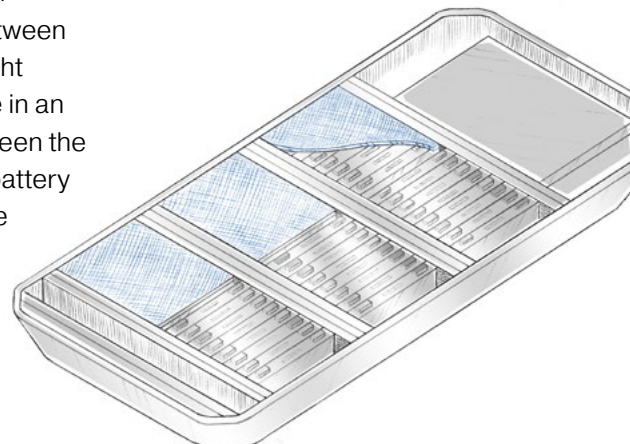

MATERIAL SPOTLIGHT

Nomex® SafePak™ Flame Barrier offers up a cost-effective, easily customizable way to prevent the spread of thermal energy and/or flames up and into the passenger cabin of the vehicle. Nomex® SafePak™ can be laminated with pressure-sensitive adhesive for ease of application to the inside of the upper lid of the EV battery pack.

HOW PRESSURE-SENSITIVE ADHESIVES CAN CONTRIBUTE TO THERMAL RUNAWAY BARRIER DESIGN

While they cannot solve thermal management challenges as standalone products, pressure sensitive adhesives (PSAs) can also contribute to thermal runaway barrier design. As a result of recent scientific advancements, acrylic- and silicone-based PSAs can now be formulated with flame-retardant properties that allow them to meet the UL® 94 V-0 standard and other additionally stringent flammability requirements. Outside of their primary functions of bonding one layer of material to the next or bonding the die-cut part to the cell, module, or pack, adhesives can also be used to encapsulate dusty or flaky materials or to add dielectric strength to aid in the prevention of spark and flame producing electrical arcing and shorting across sensitive battery cells. What's more, we can show you how adding pull tabs to the release liner of your flame-retardant PSA-backed thermal insulation, cell-separators, and pack barriers can increase assembly efficiency and lower production costs.

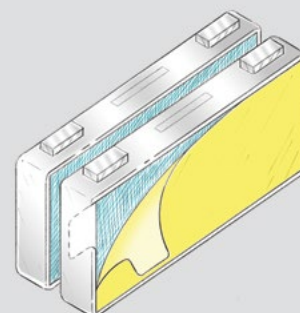

For more information, visit Avery Dennison Performance Tapes, [EV Battery Adhesive & Tape Solutions](#) page.

FROM ROLL GOODS TO FINISHED PART -

Converting Concepts into Reality

Cost-effective, location-specific and assembly line ready, JBC's die-cut specialty thermal management solutions don't stop at the part, they continue throughout the supply chain and can be found in the many ways we provide value over and above simple adhesive-backed foam gaskets.

→ **Stacking/Lamination**

Whether it's the combination of thin aluminum foil over polyester/fiberglass insulation or the application of heat-sensitive adhesive to both sides of a ceramic compression pad, sandwiching specialty materials together provides more bang for the thermal management buck.

→ **Pull Tabs**

During the assembly of the EV battery modules and packs, fast and efficient assembly is critical. Many of our parts include an adhesive backing for assembly and alignment purposes. Time spent removing this backing can make or break an assembly process. Our integrated pull-tabs enable fast manual and automated removal of sacrificial liners prior to assembly.

→ **Kiss Cutting**

Presenting custom die-cut parts on rolls is one more way we add value to the EV battery assembly process. Kiss cutting enables the fast, damage-free removal of parts from the release liner thereby supporting their efficient and accurate placement during in-line assembly.

→ **Kitting**

Our kitting service is designed to lower both purchasing and inventory costs. By providing kits of custom-labeled, rolled and die-cut components we're helping to ensure that they're ready when needed while lowering the impact of part maintenance costs.

→ **Inventory Management**

Providing just in time (JIT) delivery, on-site inventory management, and stock-keeping programs can help effectively manage our customer's carrying costs and improve manufacturing throughput.

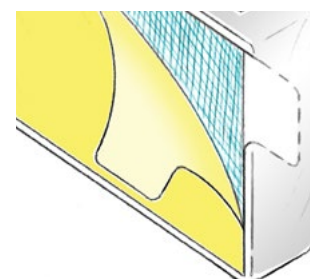

WHY JBC?

When you choose to work with JBC during the early stages of your EV battery thermal management project, you're able to leverage our unparalleled network of industry suppliers and manufacturers from the very beginning, essentially making our connections your connections.

With our decades-long relationships with North America's premier manufacturers of foams, films, flexible graphite, metal foils, and insulation, we'll provide you with the advice and timely answers you need for your thermal management material selection questions. And, when an off-the-shelf material isn't enough, we'll work with you and our manufacturer partners to develop the custom materials needed to meet your specific design requirements. We'd love to learn about your EV battery thermal management project, so why not [contact us today!](#)



www.jbc-tech.com | 440.327.4522

Corporate Headquarters | 7887 Bliss Parkway, North Ridgeville, OH 44039

