

Double-Coated Closed Cell Foam Tape

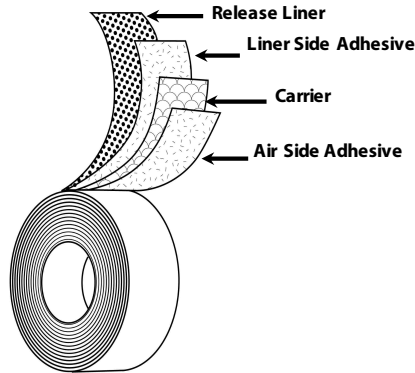

- Liner:** 60lb bleached super calendered kraft, silicone release treated on both sides
- Liner Side Adhesive:** Non-sensitizing acrylic (M109)
- Backing/Carrier:** 1/16" white, closed cell crosslinked polyethylene foam
- Air Side Adhesive:** Non-sensitizing acrylic (M109)

Applications

- Electrodes: ECG, EKG, TENS
- Medical device assembly
- Medical device attachment

Features

- Polyethylene Foam Carrier
- Non-Sensitizing Acrylic Adhesive
- 60lb Release Liner

Benefits

- Soft and flexible for maximum patient comfort
- Conformable to adapt to medical devices and body contours
- High tack and good shear for a variety of applications
- Stable to EtO and gamma sterilization
- Easy to die-cut and convert

Typical Test Values

	Standard UOM	Metric UOM	Test Method
Total Thickness w/liner	68.5 mils	1.740 mm	PSTC 133
Adhesive Thickness (Air Side)	1.1 mils	0.028 mm	PSTC 133
Adhesive Thickness (Liner Side)	1.4 mils	0.036 mm	PSTC 133
Carrier Thickness	62.5 mils	1.588 mm	PSTC 133
Liner Thickness	3.5 mils	0.089 mm	PSTC 133
Adhesion to Steel (Air Side)	160 oz/in	17.50 N/cm	PSTC 101 Mod
Adhesion to Steel (Liner Side)	160 oz/in	17.50 N/cm	PSTC 101 Mod

Product Safety

The base adhesives in this medical product have been tested in accordance with ISO 10993 and found to be non-cytotoxic, non-sensitizing, and non-irritating. The adhesive in this product has also been tested on humans via Repeat Insult Patch Test and did not induce irritation or allergic contact dermatitis in subjects.

In accordance with FDA cGMP requirements, Berry reminds the customer that ultimate fitness for use must be determined by the manufacturer of the finished device.

Recommended Storage Conditions: 40-60% Humidity, 60°F-80°F

The information presented herein was prepared at BERRY GLOBAL, INC. (25 Forge Parkway Franklin, MA 02038) by qualified technical personnel. To BERRY's knowledge it is true and accurate. However, the information and recommendations are furnished for these products with the understanding that the purchaser or user, as the case may be, will independently determine that the product is suitable for the intended use, and that such use complies with all applicable federal, state and local laws and regulations. The data are submitted only for the user's information and consideration, and do not constitute a warranty of any kind (including but not limited to a warranty of merchantability or of fitness for a particular purpose), or a representation for which BERRY assumes any legal responsibility.