

# CONVERTED MATERIAL SOLUTIONS TO PROMOTE ELECTRIC VEHICLE **SAFETY, PERFORMANCE, ENERGY EFFICIENCY & COMFORT.**

**Applications for Die-Cut  
Parts in and around the  
Battery Pack**

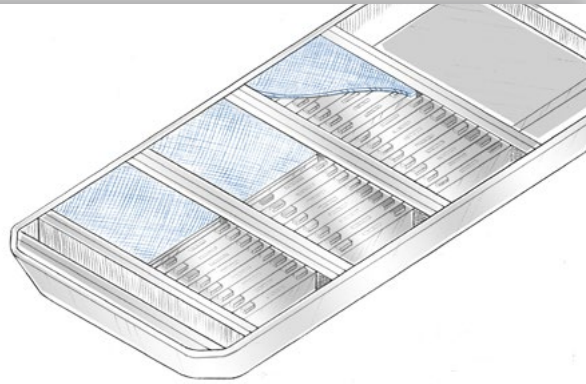

## **REDUCE NVH ISSUES**

Take advantage of cushioning foams to protect BEV components, mitigate unwanted sound, and prevent damage caused by uncontrolled vibrations.

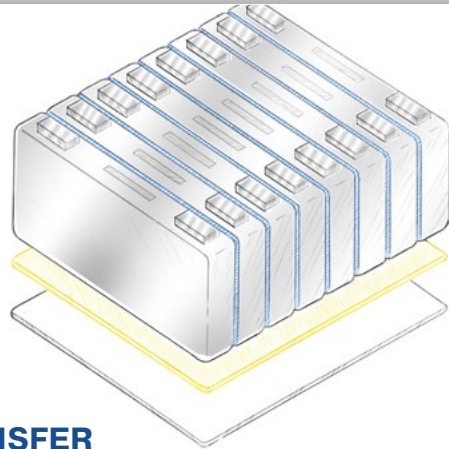

## **TRANSFER UNWANTED HEAT**

Use custom die-cut gap pads to create a thermal path between the cells or module and the heat sink.

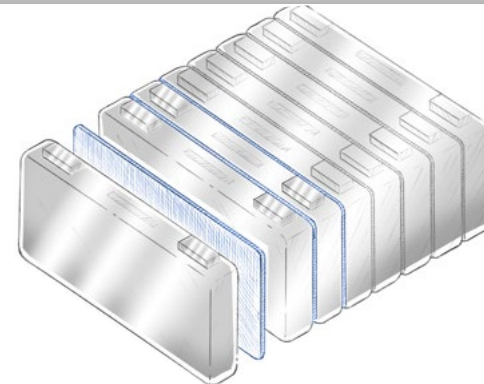

## **PROTECT SENSITIVE CELLS**

Leverage JBC's diverse converting capabilities to laminate materials together and die-cut to shape for optimum thermal and compression performance.

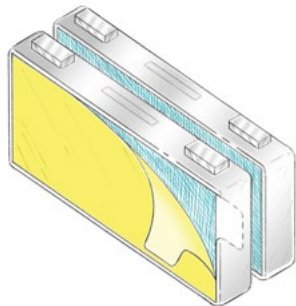

## **BOND CELLS AND OTHER COMPONENTS**

Choose from a variety of single and double-coated flame retardant tapes—custom die-cut with pull tabs for easy assembly in your automated process.

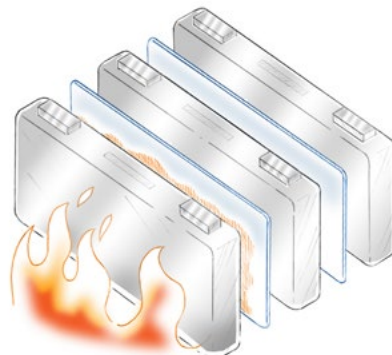

## **MITIGATE THERMAL RUNAWAY**

Turn to JBC for single or multi-layer high compression pads designed to minimize negative thermal effects on neighboring cells.



## **SEAL OUT ENVIRONMENTAL CONTAMINANTS**

Prevent the ingress of environmental elements and dampen BSR and NVH with custom die-cut seals and gaskets.

JBC's sales, technical teams and process engineers have well over a century of experience helping OEMs and tier suppliers solve complex converting and material selection challenges—**converting their concepts into reality** one die-cut component at a time.



**Contact Us Today**

[sales@jbc-tech.com](mailto:sales@jbc-tech.com)

[www.jbc-tech.com](http://www.jbc-tech.com)

440.387.4522

